

DEPARTMENT OF WORKS AND SUPPLY

MANUAL FOR THE DESIGN OF  
DRAINAGE STRUCTURES FOR  
RURAL ROADS

VOLUME 1  
DESIGN NOTES

## CONTENTS

Section	Title
1	General Notes
2	Culvert Design
3	Channel Flow
4	Erosion Control
5	Causeways

**SECTION 1**  
**GENERAL NOTES**

**Calculation of run-off**

1.1 The determination of the volume of run-off from a catchment is the first and probably the most important step in culvert design. In Papua New Guinea the calculation is subject to a great many variables and the designer should refer to the Department's Flood Estimation Manual for guidance. The manual describes five methods of calculating run-off depending on catchment size, and wherever possible at least two methods should be used.

**Return Period**

1.2 The selection of the return period depends on a number of factors. On rural roads the effect of a flood overtopping or washing away the road must be considered as must the effect on agriculture and property and the possible danger to life in the vicinity of the water course due to flood waters backing up behind a culvert. Table 1.2 gives guidance on the selection of a return period for the design storm for the three categories of road; generally the culvert will be designed to take a design flow which does not exceed level A, see Fig. 1.2 (the top of the headwall or bank protection as the case may be) and the return period to be used is given in Column A, Table 1.2. The culvert capacity should then be checked to ensure that the flood level due to a storm of the return period shown in Column B, Table 1.2 does not come within 0.3m of the road shoulder. Should level B be lower than level A the culvert should be designed for the return period shown in column

B. Local conditions, ie buildings in the vicinity of the head water pond, may limit the depth of headwater to below that given in Table 2.1

1.3 Where it is anticipated that the flow through a culvert will carry floating debris the effect of designing to allow headroom for the debris to pass through should be investigated. It is not possible to lay down rigid rules but this approach will generally be considered for banks of culverts of 1.5 m diameter or larger; the headwater depth being limited to  $0.5 D$  or  $D - 1.0$  m whichever is the greater. When considering this approach the designer should take into account the damaging effect of the road being overtopped because the culvert is blocked. With small flow the damage will be slight and a larger culvert with headroom will not be warranted. For large flows however, particularly with high velocities, the damage to a road caused by overtopping can be considerable and allowance should be made to pass floating debris through the culvert.

**Culvert or Bridge**

1.4 Once the run-off has been calculated the decision has to be made as to whether a culvert or a bridge is to be constructed. Although it is possible to construct culverts to carry very large volumes of water they are generally not desirable in Papua New Guinea, where streams and rivers carry large loads of damaging debris. This debris can erode the fabric of the culvert causing premature failure and it can also cause blockages considerably reducing the capacity of the culvert.

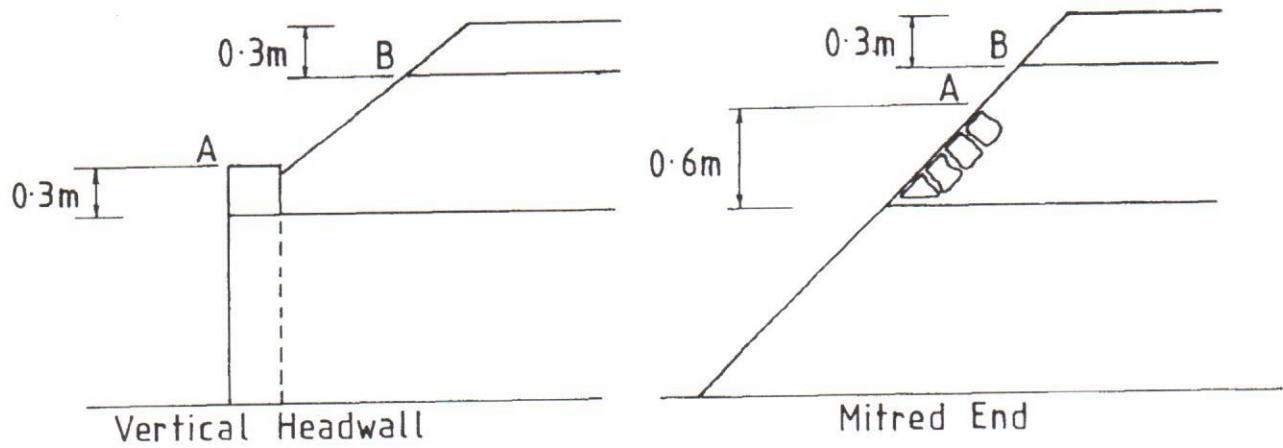

Fig 1.2 Design Flood Levels

Traffic Category	Return Period (years) for Head Water to reach	
	A	B
Heavy (>450 v.p.d.)	20	50
Medium (120 - 500 v.p.d.)	10	20
Light (20 - 160 v.p.d.)	2	10

Table 1.2 Return Periods for Design Flood Levels

1.5 Again it is not possible to lay down rigid rules but the designer should investigate the possibility of a bridge as against a culvert when the design flow is in excess of 50 cumecs. The factors to take into account would be; the debris carrying potential of the river, the type of debris, the velocities of flow in the natural channel, through the culvert and under the bridge, the shape of the stream cross-section and the cost.

#### **Structural Design of Culverts**

1.6 Corrugated steel pipes shall be manufactured to AS 2041 - Specification for Corrugated Steel Pipes, Pipe Arches and Arches. For design purposes reference shall be made to AS 2042 - Design and Installation of Corrugated Steel Pipes, Pipe Arches and Arches. For pipes up to 2.0m diameter the tables in AS 2042 can be used to determine sheet thickness, for pipes 2.0m diameter and above the structural adequacy of the culvert shall be checked in accordance with Sections 1 and 2 of AS 2042.

1.7 Precast concrete pipes shall be manufactured in accordance with AS 1342 - Precast Concrete Drainage Pipes. The design of a concrete pipe installation

shall be in accordance with AS CA33 - Recommended Practice for Concrete Pipe Laying Design.

1.8 Any concrete drainage structure outside the scope of AS 1342 (i.e. pipes with an internal diameter greater than 2.1m and all box culverts) should be referred to the Executive Engineer Bridges for structural design.

#### **Installation of Culverts**

1.9 A well situated, properly bedded, accurately assembled and carefully backfilled drainage structure will function properly and efficiently for a long period of time. Care taken by site staff at the time of installation will pay handsome dividends in terms of extended life, increased hydraulic efficiency and reduced maintenance.

1.10 The design standards for drainage structures mentioned in paragraphs 1.6 and 1.7 both assume a good standard of installation with well prepared beds, suitably graded and well compacted backfill and adequate cover. Poor materials and workmanship will stress the structure beyond its design limits and cause premature failure. This can be avoided by following the guidelines for installation in AS 2042 for corrugated steel pipes and AS CA33 for concrete pipes.

## SECTION 2

### CULVERT DESIGN

#### Introduction

2.1 Where culverts are the appropriate method of handling the design flow, the options available to the designer are set out in paragraphs 2.2 to 2.5. The selection of any structure should be based on hydraulic principles, on the most economical size and shape, and with a resulting headwater depth which will not cause damage to adjacent property. For large floodways, a cost comparison of alternatives should be carried out.

2.2 Firstly the design could be such that all the water would be passed under the roadway embankment without any risk of overtopping. This will be necessary if overtopping causes extensive damage or the requirement for embankment protection is very expensive. Immunity against overtopping for a flood, the return period of which is twice that for the design flood, would normally be sufficient. This would be the criteria in urban areas.

2.3 Secondly, the culvert could be designed so that all the water would pass under the roadway embankment with the risk of overtopping for floods of frequency greater than that shown in table 1.2 column B. This approach may be quite acceptable provided the embankment is of fairly stable material and where immunity against overtopping is not a major consideration. Culverts on rural roads would be designed to these criteria.

2.4 Thirdly, the design could be such that a portion of the

design flow passes through the culvert and the remainder passes over the embankment. This type of structure is known as a causeway and they are considered in Section 5.

2.5 In each case where water may overtop the embankment, consideration should be given to deciding whether the vertical alignment of the embankment should be flattened to enable a vehicle to pass through a length of shallow water or whether a vertical curve could be graded into an embankment to ensure the water crosses at one point. Protection to the downstream (and upstream) embankment may then be required: this is considered in more detail in Sections 4 and 5.

#### Typical operating conditions

2.6 Laboratory tests and field observations show two major types of culvert flow:

- (a) flow with inlet control,
- (b) flow with outlet control.

The hydraulic capacity of the culvert varies considerably depending on the type of control.

2.7 The parameters to be considered with inlet control are the cross sectional area of the culvert barrel, the inlet geometry and the depth of headwater or ponding at the entrance. In addition, the velocity resulting from inlet control must be acceptable. Inlet control means that the discharge capacity of a culvert is controlled at the entrance by the depth of headwater (HW), the entrance geometry, including the barrel shape and cross-sectional area, and the type of inlet edge.

**CLASS 1.**

Free water surface

$HW < 12D$

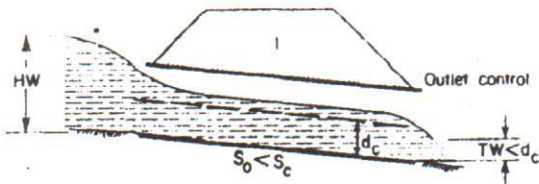

\* Common with flat grades and wide flat flood plains.

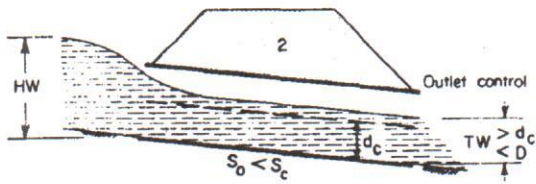

\* Common where channel is deep, narrow and well defined with a flat slope.

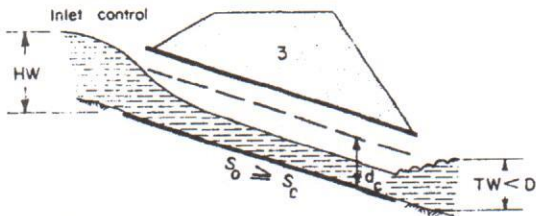

\* Common in rolling or mountainous country.

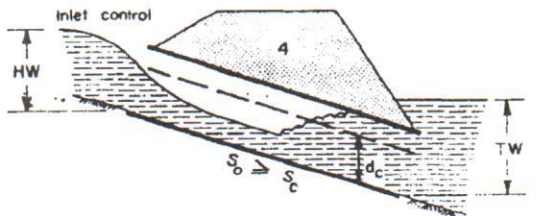

\* Not stable. Will easily convert to type 7 or 8.

\* Terrain conditions  
 HW Headwater  
 TW Tailwater  
 H Head

**CLASS 2.**

Submerged entrance

$HW > 12D$

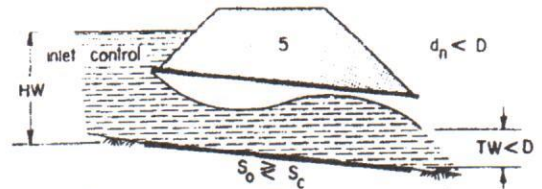

\* Common in all terrains.

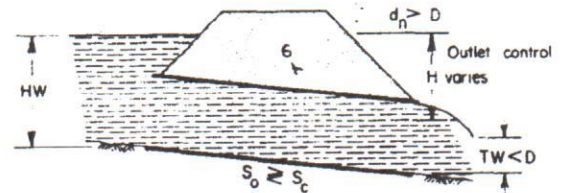

\* Common. Difficult to predict whether 5 or 6 in operation.

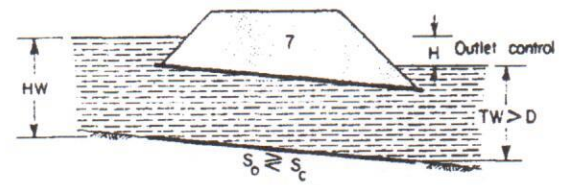

\* Common in all terrains.

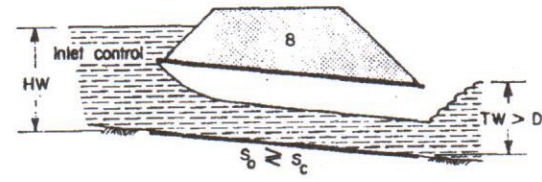

\* Common version of 7 when velocities are high.

D Diameter or height of barrel  
 dc Critical depth  
 So Slope of culvert barrel  
 Sc Critical slope

**Typical conditions under which standard culverts operate**

FIG 2.9